

ROTA

angelettiruzza design



■ CRISTINA
RUBINETTERIE



Contemporary Collection

La collezione è continuamente arricchita dall'apporto creativo dei designer che collaborano con CRISTINA Rubinetterie. Un vero e proprio racconto progettuale che definisce il vivere quotidiano, grazie a prodotti che trovano nella modernità dei canoni estetici la loro ragion d'essere.

The collection is constantly enriched by the creative contribution of the designers who work with CRISTINA Rubinetterie. A true design story that defines everyday life, thanks to products that find their reason for being in the modernity of their aesthetic canons.



Rota, angelettiruzza design

Una collezione senza tempo dove la sostanza trionfa sull'apparenza e il rigore della sintesi esalta la vitalità della materia. L'apparente essenzialità meccanica, ingloba un concentrato di simboli. Quello che ad un primo sguardo può apparire come un design scevro di qualsiasi tenerezza, evoca nel tempo dell'approfondimento, simboli e significati arcaici e potenti.

A timeless collection where substance triumphs over appearance, and the rigor of synthesis enhances the vitality of matter. The apparent mechanical essentiality encompasses a concentration of symbols. What may at first glance appear as a design devoid of any tenderness, evokes in the time of deeper exploration, ancient and powerful symbols and meanings.







Guardando la manopola dall'alto appare un punto circondato da un cerchio: presso i popoli primitivi questa era la raffigurazione del Sole e dell'Oro.

Looking at the knob from above, a point surrounded by a circle appears: among primitive peoples, this was the depiction of the Sun and Gold.



Rimane il richiamo al mondo industriale con i suoi ingranaggi e alla sua estetica austera e ruvida eppure ROTA offre un'emanazione superiore, più elevata, legata al simbolismo antichissimo e sacro del cerchio, al mu giapponese (il vuoto orientale, che non è veramente vuoto, non è propriamente non-essere ma un essere in potenza, è energia), alla ruota che rappresenta il continuo movimento della vita.

The reference to the industrial world with its gears and austere, rough aesthetics remains, yet ROTA offers a higher, more elevated emanation, linked to the ancient and sacred symbolism of the circle, the Japanese mu (the eastern void, which is not truly empty, not properly non-being but rather potential energy), to the wheel that represents the continuous movement of life.





Un'anima industrial e sofisticata allo stesso tempo : è chiaro il riferimento al volante di manovra a tre razze dei torni meccanici, che si amalgama con la naturale eleganza suggerita dal piedistallo. E' proprio il fatto di essere sollevata dalla base e circondata dal vuoto, a donare alla maniglia ROTA un'allure di pregio, che la rende in grado di arredare con raffinatezza bagni eleganti.

An industrial and sophisticated soul at the same time: the reference to the three-spoke control wheel of mechanical lathes is evident, which merges with the natural elegance suggested by the pedestal. It is precisely the fact of being lifted from the base and surrounded by emptiness that gives the ROTA handle an allure of value, making it capable of elegantly furnishing stylish bathrooms.



angelettiruzza design_Bio

Silvana Angeletti e Daniele Ruzza progettano oggetti essenziali, capaci di resistere nel tempo e in grado di entrare in relazione con gli ambienti e le persone. Sono designer industriali dal 1994, quando Guzzini ha messo in produzione la loro caffettiera Zazà, ancora a catalogo.

Hanno collaborato con numerose realtà industriali italiane nei settori dell'arredamento, illuminazione, complementi d'arredo, elettrodomestici e arredobagno. Promuovendo la contaminazione e la sperimentazione nei diversi ambiti hanno sempre saputo mantenere un dialogo aperto con gli interlocutori del progetto.

Silvana Angeletti and Daniele Ruzza design essential objects, capable of lasting over time and able to relate to environments and people. They have been industrial designers since 1994, when Guzzini put their Zazà coffee maker into production, still on catalogue.

They collaborated with numerous Italian industrial companies in the sectors of furniture, lighting, furnishing accessories, household appliances and bathroom furniture. Supporting contamination and experimentation in different areas and always maintaining an open dialogue with the project partners.

L'estetica dei loro prodotti nasce nella sintesi tra funzione, cura dei dettagli e conoscenza delle tecniche produttive. Quest'approccio concreto alla progettazione è stato alla base dell'insegnamento ai corsi di Industrial Design dell'Università di Ascoli Piceno (dal 2012 al 2014) e dello IED di Roma (dal 2010 al 2018).

The aesthetics of their products come from the synthesis between function, attention to detail and production techniques knowledge. This concrete approach to design has always been the basis for teaching at the Industrial Design courses at the University of Ascoli Piceno (from 2012 to 2014) and at the IED in Rome (from 2010 to 2018).

*"L'apparente essenzialità meccanica di ROTA ingloba un concentrato di simboli"
"The apparent mechanical essentiality of ROTA encompasses a concentration of symbols"*

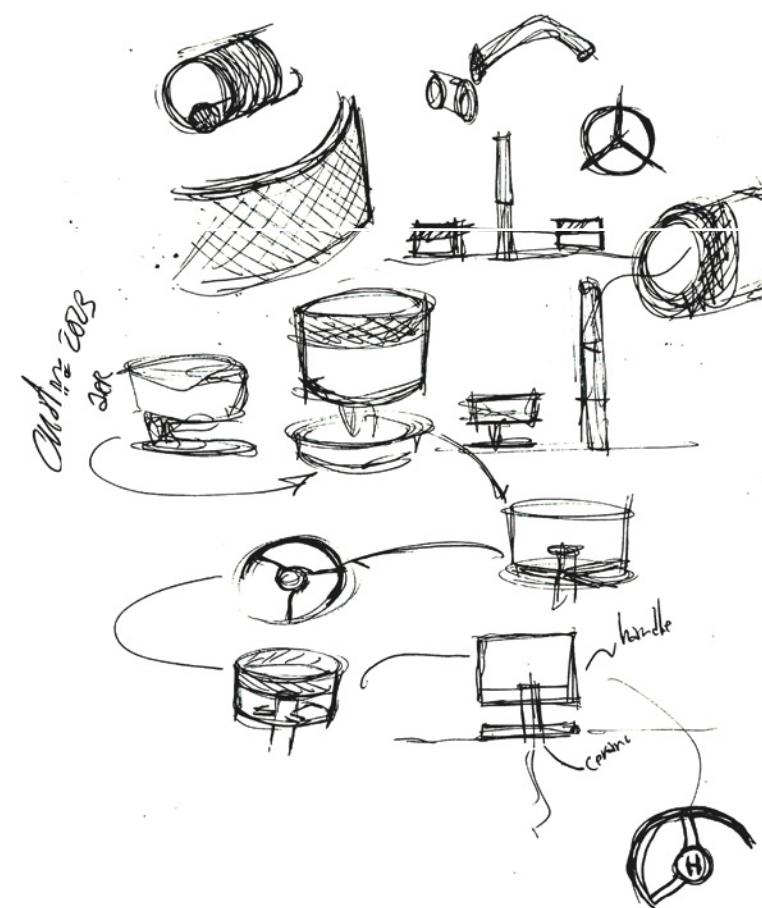

Angeletti e Ruzza sono stati direttori artistici di varie aziende. Oggi di Bottega Intreccio, Kalon e Globo. Hanno saputo spingere le imprese al di fuori della loro "comfort zone", capendone l'identità e il know-how produttivo, promuovendo nuove tipologie di prodotto e spunti di ricerca su materiali, tecniche e, più in generale, bisogni di vita. Alcuni loro prodotti fanno parte della collezione permanente del Chicago Athenaeum Museum e molti altri sono stati insigniti dei più importanti riconoscimenti di design internazionali. Premi che hanno accreditato l'innovazione di prodotto, ma anche la capacità di progetto in ambiti come la grafica o gli allestimenti.

Angeletti and Ruzza have been artistic directors of various companies during the years and today of Bottega Intreccio, Kalon and Globo.

They have been able to push companies outside of their "comfort zone", understanding their identity and productive know-how, promoting new types of products and research ideas on materials, techniques and, more generally, life needs. Some of their design products are part of the permanent collection of the Chicago Athenaeum Museum and many others have been awarded the most important international design awards. Awards that have confirmed product innovation, but also the ability to design in areas such as graphics or installations.

Il Rubinetto come architettura The faucet as architecture

“La rubinetteria in bagno è fondamentale, come la maniglia sulla porta. Quando progettiamo cerchiamo sempre di immaginare come sarà l’ambiente che la ospiterà e chi la potrebbe utilizzare. Rota è una collezione classica, pulita, scevra, ma a nostro parere esige un contesto strutturato, importante”. In un buon progetto i percorsi tecnico-creativi sono complessi, fatti di rimandi colti, hanno radici profonde non solo dal punto di vista del design quanto dal punto di vista intimo e psicologico, sono narrazione di sé e dell’universale: “La mano che agisce su East Side è aperta, mentre quella su Rota è chiusa, concentrata su se stessa, ha un senso di maggior potere”.

“The bathroom faucet is fundamental, like the handle on the door. When we design, we always try to imagine the environment that will host it and who might use it. Rota is a classic, clean, pure collection, but in our opinion, it requires a structured and significant context.” In a good project, the technical and creative paths are complex, made of cultured references, with deep roots not only from a design perspective but also from an intimate and psychological point of view, and are a narration of the self and the universal: “The hand that acts on East Side is open, while the hand on Rota is closed, concentrated on itself, and has a sense of greater power”.



La nuova collezione Rota per CRISTINA Rubinetterie fa seguito alle pluripremiate serie Tabula e East Side, disegnate dagli stessi autori. “Fin dalle prime battute - racconta Silvana Ruzza - ho concepito Rota come un progetto di sottrazione, di confronto con il vuoto, ricca dei tanti significati simbolici del cerchio”. Pur condividendo alcuni elementi con East Side - l’apparente ruvidità dello stile industrial chic, l’accurato lavoro di godronatura e la tipologia tre fori - le due serie sono profondamente diverse. A volte è sufficiente cambiare un dettaglio per evocare altri mondi.

The new Rota collection for CRISTINA Rubinetterie follows the multi-award-winning Tabula and East Side series, designed by the same authors. “From the very beginning,” says Silvana Ruzza, “I conceived Rota as a project of subtraction, a confrontation with the void, rich in the many symbolic meanings of the circle.” While sharing some elements with East Side - the apparent roughness of the industrial chic style, the careful grooving work, and the three-hole typology - the two series are profoundly different. Sometimes, changing a detail is enough to evoke other worlds.

“Nel progettare - continuano i designer - è necessario essere semplici e incisivi. All’estetica della ruota, dell’utensile, del fattore meccanico che troviamo in Rota si aggiungono gli elementi del vuoto e del cerchio, la cui simbologia dai molti significati tocca l’ancestrale. In uno sguardo dall’alto, l’immagine che deriva da Rota è quella di un cerchio esteso ed esterno sormontato da un altro cerchio più piccolo quasi galleggiante, attorno a cui c’è il vuoto in un confine staccato”. Una “magia” realizzata con l’indispensabile ingegnerizzazione compiuta dall’ufficio tecnico dell’azienda - CRISTINA Design Lab - alla continua ricerca del delicato equilibrio tra forma e funzione. La manopola risulta infatti sospesa grazie all’espedito del fissaggio mascherato posto alla base, mentre le due cartucce ceramiche sono mimetizzate all’interno del piano del lavabo.

“In design,” the designers continue, “it is necessary to be simple and incisive. The aesthetics of the wheel, the tool, the mechanical factor that we find in Rota, are added to the elements of the void and the circle, whose symbolism touches the ancestral with its many meanings. In a top-down view, the image that derives from Rota is that of an extended and external circle surmounted by a smaller circle that is almost floating, around which there is a detached boundary of emptiness.” This “magic” is achieved with the indispensable engineering carried out by the company’s technical office - CRISTINA Design Lab - in the continuous search for the delicate balance between form and function. The knob is suspended thanks to the concealed fixing device placed at the base, while the two ceramic cartridges are camouflaged inside the sink’s surface.

Altrettanto interessante è il motivo della godronatura - “L’ispirazione è nata dall’accendino Dupont” - lavorata per ottenere una texture sottile, leggera, tattile in un giusto gradiente decorativo e al contempo funzionale, in quanto questa zigrinatura facilita la presa, soprattutto con le mani bagnate. In un necessario e proficuo confronto con l’azienda i designer hanno valutato tutti i dettagli tecnici, bilanciando il rapporto tra le parti decorate e quelle lisce, la proporzione tra la sospensione e l’altezza del cilindro, valutando il peso della maniglia.

Equally interesting is the reason for the grooving - “The inspiration came from the Dupont lighter” - worked to obtain a thin, light, and tactile texture in a proper decorative gradient and at the same time functional, as this corrugation facilitates grip, especially with wet hands. In a necessary and productive dialogue with the company, the designers evaluated all the technical details, balancing the relationship between the decorated and smooth parts, the proportion between the suspension and the height of the cylinder and evaluating the weight of the handle.

Finiture
Finishings



13

Nero opaco
Black matt
RAL 9005



34P

Oro rosa
spazzolato PVD
Brushed rose
gold PVD



46P

Oro rosa
lucido PVD
Polished rose
gold PVD



51

Cromo
Chrome



75

Cromo nero
spazzolato
Brushed black
chrome

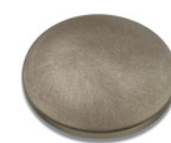

77

Metallic
spazzolato
Brushed metallic



96P

Gold brass
spazzolato PVD
PVD brushed gold
brass

La serie offre una gamma completa di articoli con numerose finiture.
The series offers a complete range of items with numerous finishes.



Technical info

CRIRT226
REGULAR



IT Miscelatore bicomando Lavabo Regular monoforo da piano, con miscelazione meccanica
 DE 1-Loch Zweigriff-Waschtischbatterie Regular, mit mechanischer Mischung
 FR Mélangeur double commande de Lavabo Regular monotrou sur plage, réglage mécanique
 EN Regular dual-control deck-mounted single-hole washbasin mixer, with mechanical mixing
 ES Mezclador bimando para lavabo Regular, 1 orificio, de repisa, con mezcla mecánica

CRIRT226

51 cromo 13 nero opaco 34P oro rosa spazzolato PVD 46P oro rosa lucido PVD 75 cromo nero spazzolato 77 metallic spazzolato

96P gold brass spazzolato PVD

CRIRT926

51 cromo



CRIRT926
REGULAR

CRIRT248
TALL



IT Miscelatore bicomando Lavabo Tall monoforo da piano, con miscelazione meccanica
 DE 1-Loch Zweigriff-Waschtischbatterie Tall, mit mechanischer Mischung
 FR Mélangeur double commande de Lavabo Tall monotrou sur plage, réglage mécanique
 EN Tall dual-control deck-mounted single-hole washbasin mixer, with mechanical mixing
 ES Mezclador bimando para lavabo Tall, 1 orificio, de repisa, con mezcla mecánica

CRIRT248

51 cromo 13 nero opaco 34P oro rosa spazzolato PVD 46P oro rosa lucido PVD 75 cromo nero spazzolato 77 metallic spazzolato

96P gold brass spazzolato PVD

CRIRT948

51 cromo



CRIRT948
TALL

CRIRT226

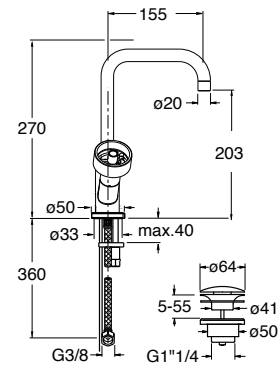

5,6 1/2 min (3 bar)

CRIVT5889Q00

CRIVT5890Q00

CRIRT204
SMALL



IT Miscelatore bicomando Lavabo Small 3 fori da piano, con miscelazione meccanica
 DE 3-Loch Zweigriff-Waschtischbatterie Small, mit mechanischer Mischung
 FR Mélangeur double commande de Lavabo Small 3 trous sur plage, réglage mécanique
 EN Small dual-control deck-mounted 3-hole washbasin mixer, with mechanical mixing
 ES Mezclador bimando para lavabo Small, 3 orificios, de repisa, con mezcla mecánica

CRIRT204

51 cromo 13 nero opaco 34P oro rosa spazzolato PVD 46P oro rosa lucido PVD 75 cromo nero spazzolato 77 metallic spazzolato

96P gold brass spazzolato PVD

CRIRT904

51 cromo



CRIRT904
SMALL

CRIRT205
REGULAR



IT Miscelatore bicomando Lavabo Regular 3 fori da piano, con miscelazione meccanica
 DE 3-Loch Zweigriff-Waschtischbatterie Regular, mit mechanischer Mischung
 FR Mélangeur double commande de Lavabo Regular 3 trous sur plage, réglage mécanique
 EN Regular dual-control deck-mounted 3-hole washbasin mixer, with mechanical mixing
 ES Mezclador bimando para lavabo Regular, 3 orificios, de repisa, con mezcla mecánica

CRIRT205

51 cromo 13 nero opaco 34P oro rosa spazzolato PVD 46P oro rosa lucido PVD 75 cromo nero spazzolato 77 metallic spazzolato

96P gold brass spazzolato PVD

CRIRT905

51 cromo



CRIRT905
REGULAR

CRIRT204

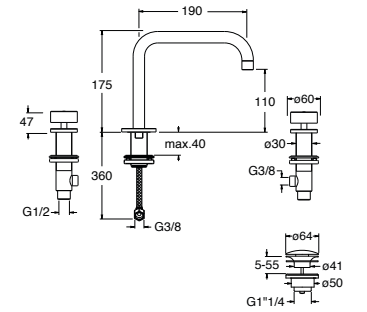

5,6 1/2 min (3 bar)

CRIVT6687Q00

CRIVT6875Q00

CRIRT205

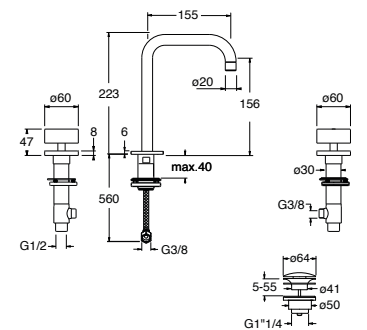

5,6 1/2 min (3 bar)

CRIVT6687Q00

CRIVT6875Q00

CRIRT206

TALL



- IT Miscelatore bicomando Lavabo Tall 3 fori da piano, con miscelazione meccanica
- DE 3-Loch Zweigriff-Waschtischbatterie, mit mechanischer Mischung
- FR Mélangeur double commande de Lavabo Tall 3 trous sur plage, réglage mécanique
- EN Tall dual-control deck-mounted 3-hole washbasin mixer, with mechanical mixing
- ES Mezclador bimando para lavabo Tall, 3 orificios, de repisa, con mezcla mecánica

CRIRT206

51 cromo	13 nero opaco	34P oro rosa spazzolato PVD	46P oro rosa lucido PVD	75 cromo nero spazzolato 77 metallic spazzolato
----------	---------------	--------------------------------	----------------------------	--

96P gold brass
spazzolato PVD

CRIRT906

51 cromo



CRIRT906

TALL

CRIRT242

REGULAR



- IT Set esterno bicomando Lavabo Regular 3 fori a parete, con miscelazione meccanica, bocca con punto d'erogazione 180 mm, da completarsi con parte incasso CRICS233 (comandi laterali), CRICS234 (comando a destra)
- DE 3-Loch Fertigmontageset Zweigriff-Waschtischbatterie für Wandmontage Regular, mit mechanischer Mischung,, Auslauflänge 180 mm, zu vervollständigen mit Unterputz-Einbakörper CRICS233 (seitliche Kartuschen) CRICS234 (rechte Kartuschen)
- FR Groupe extérieur double commande mural de Lavabo Regular 3 trous, réglage mécanique, bec déverseur longueur 180 mm, à compléter avec le corps d'encastrement CRICS233 (commandes latérales) CRICS234 (commandes à droite)
- EN Regular external dual-control wall-mounted 3-hole washbasin set, with mechanical mixing, spout length 180 mm, for completion with recessed part CRICS233 (controls on the sides) CRICS234 (controls on the right)
- ES Kit exterior bimando para lavabo Regular, 3 orificios, de pared, con mezcla mecánica, caño con boca de salida de 180 mm, a completar con cuerpo empotrado CRICS233 (mandos laterales) o CRICS234 (mandos a la derecha)

CRIRT242

51 cromo	13 nero opaco	34P oro rosa spazzolato PVD	46P oro rosa lucido PVD	75 cromo nero spazzolato 77 metallic spazzolato
----------	---------------	--------------------------------	----------------------------	--

96P gold brass
spazzolato PVD

CRIRT942

51 cromo



CRIRT942

REGULAR

CRIRT206

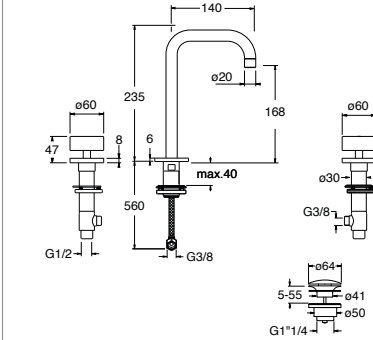

5,6 1/2 min (3 bar)

CRIVT6687Q00

CRIVT6875Q00

CRIRT242

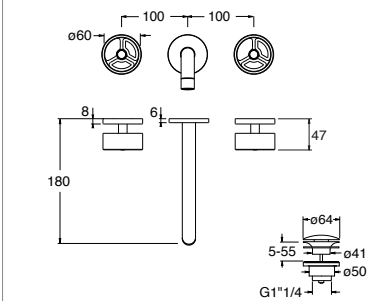

5,6 1/2 min (3 bar)

CRICS233

CRICS234

CRIVT5889Q00

CRIVT5890Q00

CRIRT243

LARGE



- IT Set esterno bicomando Lavabo Large 3 fori a parete, con miscelazione meccanica, bocca con punto d'erogazione 225 mm, da completarsi con parte incasso CRICS233 (comandi laterali), CRICS234 (comando a destra)
- DE 3-Loch Fertigmontageset Zweigriff-Waschtischbatterie für Wandmontage Large, mit mechanischer Mischung,, Auslauflänge 225 mm, zu vervollständigen mit Unterputz-Einbakörper CRICS233 (seitliche Kartuschen) CRICS234 (rechte Kartuschen)
- FR Groupe extérieur double commande mural de Lavabo Large 3 trous, réglage mécanique, bec déverseur longueur 225 mm, à compléter avec le corps d'encastrement CRICS233 (commandes latérales) CRICS234 (commandes à droite)
- EN Large external dual-control wall-mounted 3-hole washbasin set, with mechanical mixing, spout length 225 mm, for completion with recessed part CRICS233 (controls on the sides) CRICS234 (controls on the right)
- ES Kit exterior bimando para lavabo Large, 3 orificios, de pared, con mezcla mecánica, caño con boca de salida de 225 mm, a completar con cuerpo empotrado CRICS233 (mandos laterales) o CRICS234 (mandos a la derecha)

CRIRT243

51 cromo	13 nero opaco	34P oro rosa spazzolato PVD	46P oro rosa lucido PVD	75 cromo nero spazzolato 77 metallic spazzolato
----------	---------------	--------------------------------	----------------------------	--

96P gold brass
spazzolato PVD

CRIRT943

51 cromo



CRIRT943

LARGE

CRIRT330



- IT Miscelatore bicomando Bidet 3 fori da piano, con miscelazione meccanica
- DE 3-Loch Zweigriff-Mischbatterie für das Bidet, mit mechanischer Mischung,
- FR Mélangeur double commande de bidet 3 trous sur plage, réglage mécanique
- EN Dual-control deck-mounted 3-hole bidet mixer, with mechanical mixing
- ES Mezclador bimando para bidé, 3 orificios, de repisa, con mezcla mecánica

CRIRT330

51 cromo	13 nero opaco	34P oro rosa spazzolato PVD	46P oro rosa lucido PVD	75 cromo nero spazzolato 77 metallic spazzolato
----------	---------------	--------------------------------	----------------------------	--

96P gold brass
spazzolato PVD

CRIRT380

51 cromo



CRIRT380

CRIRT243

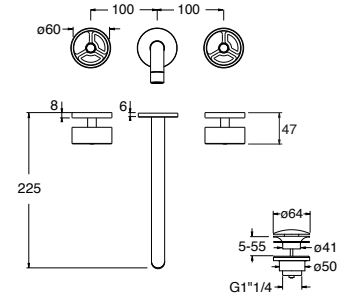

5,6 1/2 min (3 bar)

CRICS233

CRICS234

CRIVT5889Q00

CRIVT5890Q00

CRIRT330

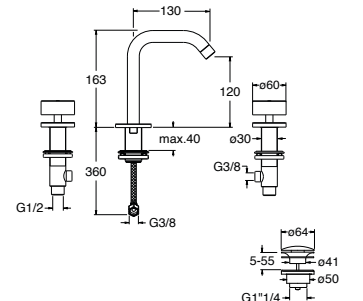

5,6 1/2 min (3 bar)

CRIVT6687Q00

CRIVT6875Q00

CRIRT326



- IT Miscelatore bicomando Bidet monoforo da piano, con miscelazione meccanica
 DE 1-Loch Zweigriff-Mischbatterie für das Bidet, mit mechanischer Mischung
 FR Mélangeur double commande de bidet monotrou sur plaque, réglage mécanique
 EN Dual-control deck-mounted single-hole bidet mixer, with mechanical mixing
 ES Mezclador bimando para bidé, 1 orificio, de repisa, con mezcla mecánica

CRIRT326

51 cromo	13 nero opaco	34P oro rosa spazzolato PVD	46P oro rosa lucido PVD	75 cromo nero spazzolato 77 metallic spazzolato
----------	---------------	-----------------------------	-------------------------	--

96P gold brass spazzolato PVD

CRIRT376

51 cromo



CRIRT376

CRIES751



- IT Set esterno doccia a parete, piastra in metallo stondata, con miscelazione termostatica, valvola d'arresto 1 uscita, da completarsi con parte incasso CRICS800
 DE Fertigmontageset Duschesystem für Wandmontage, abgerundete Abdeckplatte aus Metall, mit thermostatischer Mischung und 1-Weg-Absperrventil, zu vervollständigen mit Unterputz-Einbaukörper CRICS800
 FR Groupe extérieur mural de douche, plaque angles arrondis en métal, réglage thermostatique, vanne d'arrêt 1 sortie, à compléter avec le corps d'encastrement CRICS800
 EN External wall-mounted shower set, curved metal plate, with thermostatic mixing, 1-outlet stop valve, for completion with recessed part CRICS800
 ES Kit exterior para ducha, de pared, placa de metal redondeada, con mezcla termostática, válvula de paso de 1 salida, a completar con cuerpo empotrado CRICS800

CRIES751

Per completare l'offerta, consultare il listino pag.70
 Um das Angebot zu vervollständigen, konsultieren Sie die Preisliste auf Seite 70
 Pour compléter l'offre, consultez la grille tarifaire en page 70
 To complete the offer, consult the price list on page 70
 Para completar la oferta, consulte la lista de precios en la página 70

96P gold brass spazzolato PVD

CRIRT326

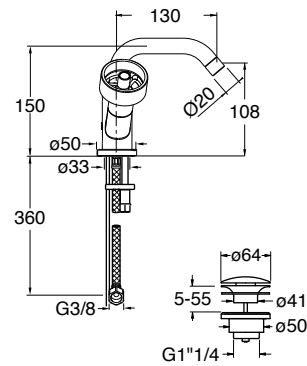

5,6 1/2 min (3 bar)

CRIVT5889Q00

CRIVT5890Q00

CRIES751

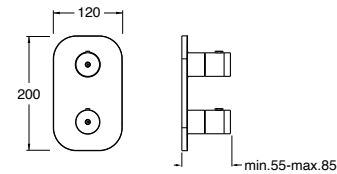

CRICS800

CRICR16901Q00

CRIES752

- IT con deviatore a 2 uscite
 DE mit 2 wenge umsteller
 FR avec inverseur 2 sorties
 EN with 2 outlet diverter
 ES con desviador 2 salidas



CRIES753

- IT con deviatore a 3 uscite
 DE mit 3 wenge umsteller
 FR avec inverseur 3 sorties
 EN with 3 outlet diverter
 ES con desviador 3 salidas

CRIRT481



- IT Set esterno doccia/vasca a parete, piastra in metallo stondata, con miscelazione termostatica, deviatore, da completarsi con parte incasso CRICS800
 DE Wand-Fertigmontageset Wanne/Brause, abgerundete Abdeckplatte aus Metall, mit thermostatischer Mischung, zu vervollständigen mit Unterputz-Einbaukörper CRICS800
 FR Groupe extérieur mural douche/baignoire, plaque angles arrondis en métal, réglage thermostatique, à compléter avec le corps d'encastrement CRICS800
 EN External wall-mounted shower/bathtub set, curved metal plate, with thermostatic mixing, for completion with recessed part CRICS800
 ES Kit exterior para ducha/bañera, de pared, placa de metal redondeada, con mezcla termostática, a completar con cuerpo empotrado CRICS800

CRIES752 / CRIES753

Per completare l'offerta, consultare il listino pag. 70
 Um das Angebot zu vervollständigen, konsultieren Sie die Preisliste auf Seite 70
 Pour compléter l'offre, consultez la grille tarifaire en page 70
 To complete the offer, consult the price list on page 70
 Para completar la oferta, consulte la lista de precios en la página 70

96P gold brass spazzolato PVD

CRIES752/CRIES753

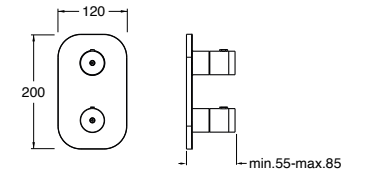

CRICS800

CRICR15442Q00

CRICR15441Q00

CRIRT481

51 cromo	13 nero opaco	34P oro rosa spazzolato PVD	46P oro rosa lucido PVD	75 cromo nero spazzolato 77 metallic spazzolato
----------	---------------	-----------------------------	-------------------------	--

96P gold brass spazzolato PVD

CRIRT481

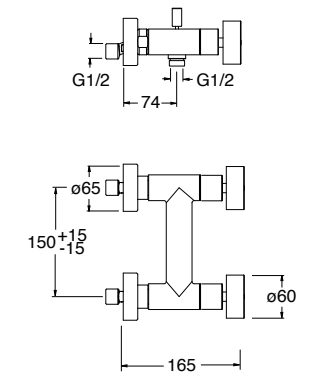

CRIVT5889Q00

CRIVT5890Q00

CRIES451



- IT Miscelatore doccia esterno a parete, con miscelazione termostatica
 DE Aufputz-Mischbatterie für Duschsystem für Wandmontage mit thermostatischer Mischung
 FR Mitigeur mural de douche extérieure, réglage thermostatique
 EN Dual-control wall-mounted external shower mixer, with thermostatic mixing
 ES Mezclador para ducha, exterior de pared, con mezcla termostática

CRIES451

Per completare l'offerta, consultare il listino pag. 71
 Um das Angebot zu vervollständigen, konsultieren Sie die Preisliste auf Seite 71
 Pour compléter l'offre, consultez la grille tarifaire en page 71
 To complete the offer, consult the price list on page 71
 Para completar la oferta, consulte la lista de precios en la página 71

CRIES451

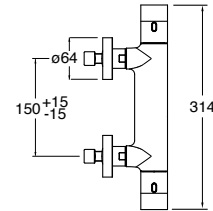
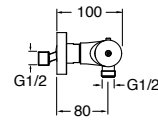

CRIRT486



- IT Colonna doccia a parete, con miscelazione termostatica, deviatore a 2 uscite, soffione anticalcare ispezionabile Ø 190 mm, braccio orientabile, doccetta anticalcare, supporto scorrevole, flessibile long life****
 DE Duschsystem für Wandmontage mit thermostatischer Mischung, 2-Wege-Umsteller, zur Reinigung demontierbarer Kopfbrause mit Antikalk-System Ø190 mm, schwenkbarem Brausearm, Handbrause mit Antikalk-System, Gleitschieber, Brauseschlauch Long Life****
 FR Colonne de douche murale, réglage thermostatique, inverseur 2 sorties, douche de tête anticalcaire accessible pour l'inspection Ø190 mm, bras orientable, douchette anticalcaire, support coulissant, flexible long life****
 EN Wall-mounted shower column, with thermostatic mixing, 2-outlet diverter, Ø190 mm inspectable anti-scale rain effect showerhead, swivel arm, anti-scale hand shower, sliding support, long-life hose****
 ES Columna de ducha de pared, con mezcla termostática, inversor de 2 salidas, rociador antical inspeccionable Ø 190 mm, brazo orientable, ducha de mano antical, soporte deslizante, flexo Long Life****

CRIRT486

51 cromo 13 nero opaco 34P oro rosa spazzolato PVD 46P oro rosa lucido PVD 75 cromo nero spazzolato 77 metallic spazzolato

96P gold brass spazzolato PVD

CRIRT486

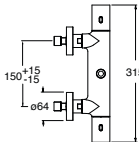
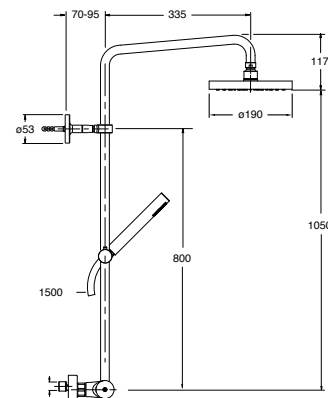

CRIRT161



- IT Set esterno bicomando doccia a parete, con miscelazione meccanica, deviatore a 2 uscite, soffione anticalcare ispezionabile Ø 190 mm, braccio a parete, doccetta anticalcare in metallo, supporto scorrevole, presa d'acqua, flessibile long life****, da completarsi con parte incasso CRICS115 (comandi laterali)
 DE Fertigmontageset Zweigriffbatterie für Duschsystem für Wandmontage, mit mechanischer Mischung, 2-Wege-Umsteller, zur Reinigung demontierbare Kopfbrause mit Antikalk-System Ø190 mm, Wandbrausearm, Handbrause mit Antikalk-System aus Metall, Gleitschieber, Wandanschlussbogen, Brauseschlauch Long Life****, zu vervollständigen mit Unterputz-Einbakörper CRICS115 (seitliche Kartuschen)
 FR Groupe extérieur double commande mural de douche, réglage mécanique, inverseur 2 sorties, douche de tête anticalcaire inspection Ø190 mm, bras mural, douchette anticalcaire en métal, support coulissant, prise d'eau, flexible long life****, à compléter avec le corps d'encastrement CRICS115 (commandes latérales)
 EN External dual-control wall-mounted shower set, with mechanical mixing, 2-outlet diverter, Ø190 mm inspectable anti-scale rain effect showerhead, wall-mounted arm, metal anti-scale hand shower, sliding support, water outlet, long-life hose****, for completion with recessed part CRICS115 (controls on the sides)
 ES Kit exterior bicomando para ducha, de pared, con mezcla mecánica, inversor de 2 salidas, rociador antical inspeccionable Ø 190 mm, brazo de pared, ducha de mano antical de metal, soporte deslizante, toma de agua, flexo Long Life****, a completar con cuerpo empotrado CRICS115 (mandos laterales)

CRIRT161

51 cromo 13 nero opaco 34P oro rosa spazzolato PVD 46P oro rosa lucido PVD 75 cromo nero spazzolato 77 metallic spazzolato

96P gold brass spazzolato PVD

CRIRT161

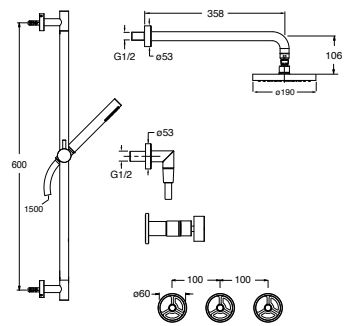

CRIRT180



- IT Miscelatore bicomando vasca esterno a parete, con miscelazione meccanica, deviatore automatico a 2 uscite, bocca con punto d'erogazione 203 mm, doccetta anticalcare in metallo, supporto fisso, flessibile long life****
 DE Aufputz Zweigriff-Wannenmischbatterie für Wandmontage, mit mechanischer Mischung, automatischem 2-Wege-Umsteller, Auslauflänge 203 mm, Handbrause aus Metall mit Antikalk-System, Halter für Wandmontage und Brauseschlauch Long Life****
 FR Mélangeur double commande mural de baignoire extérieure, réglage mécanique, inverseur automatique 2 sorties, bec déverseur longueur 203 mm, douchette anticalcaire en métal, support fixe, flexible long life****
 EN Dual-control wall-mounted external bathtub mixer, with mechanical mixing, 2-outlet automatic diverter, spout length 203 mm, metal anti-scale hand shower, fixed support, long-life hose ****
 ES Mezclador bicomando para bañera, exterior de pared, con mezcla mecánica, inversor automático de 2 salidas, caño con boca de salida de 203 mm, ducha de mano antical de metal, soporte fijo, flexo Long Life****

CRIRT180

51 cromo 13 nero opaco 34P oro rosa spazzolato PVD 46P oro rosa lucido PVD 75 cromo nero spazzolato 77 metallic spazzolato

96P gold brass spazzolato PVD

CRIRT180

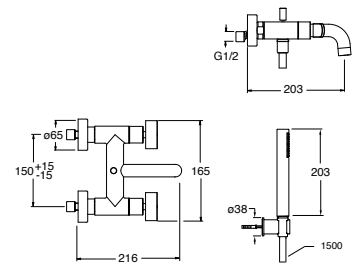

CRIRT187



- IT Miscelatore bicomando vasca esterno a parete, con miscelazione meccanica, deviatore automatico a 2 uscite, bocca con punto d'erogazione 203 mm
- DE Aufputz Zweigriff-Wannenmischbatterie für Wandmontage, mit mechanischer Mischung, automatischem 2-Wege-Umsteller und Auslauflänge 203 mm
- FR Mélangeur double commande mural de baignoire extérieure, réglage mécanique, inverseur automatique 2 sorties, bec déverseur longueur 203 mm
- EN Dual-control wall-mounted external bathtub mixer, with mechanical mixing, 2-outlet automatic diverter, spout length 203 mm
- ES Mezclador bimando para bañera, exterior de pared, con mezcla mecánica, inversor automático de 2 salidas, caño con boca de salida de 203 mm

CRIRT187

- | | | | | |
|----------|---------------|--------------------------------|----------------------------|--|
| 51 cromo | 13 nero opaco | 34P oro rosa
spazzolato PVD | 46P oro rosa
lucido PVD | 75 cromo nero
spazzolato
77 metallic
spazzolato |
|----------|---------------|--------------------------------|----------------------------|--|

96P gold brass
spazzolato PVD

CRIRT187

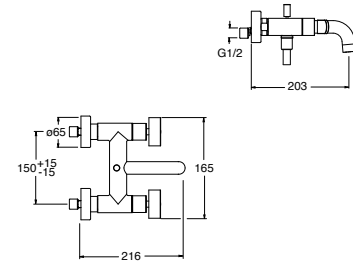

CRIVT5889Q00

CRIVT5890Q00

CRIES157



- IT Miscelatore bicomando vasca esterno a parete, con miscelazione termostatica, deviatore a 2 uscite, bocca con punto d'erogazione 190 mm
- DE Aufputz Zweigriff-Wannenmischbatterie für Wandmontage, mit thermostatischer Mischung, 2-Wege-Umsteller und Auslauflänge 190 mm
- FR Mélangeur double commande mural de baignoire extérieure, réglage thermostatique, inverseur 2 sorties, bec déverseur longueur 190 mm
- EN Dual-control wall-mounted external bathtub mixer, with thermostatic mixing, 2-outlet diverter, spout length 190 mm
- ES Mezclador bimando para bañera, exterior de pared, con mezcla termostática, inversor de 2 salidas, caño con boca de salida de 190 mm

CRIES157

Per completare l'offerta, consultare il listino pag. 73
Um das Angebot zu vervollständigen, konsultieren Sie die Preisliste auf Seite 73
Pour compléter l'offre, consultez la grille tarifaire en page 73
To complete the offer, consult the price list on page 73
Para completar la oferta, consulte la lista de precios en la página 73

CRIES157

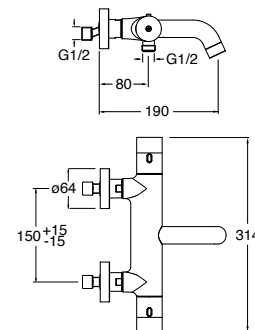

CRICR11715Q00

CRICR11713Q00

CRIRT108



- IT Miscelatore bicomando vasca 2 fori a pavimento, con miscelazione meccanica, deviatore a 2 uscite, bocca con punto d'erogazione 263 mm, doccetta anticalcare in metallo, flessibile long life****
- DE 2-Loch Zweigriff-Mischbatterie für bodenstehende Wanne, mit mechanischer Mischung, 2-Wege-Umsteller, Auslauflänge 263 mm, Handbrause aus Metall mit Antikalk-System, Brauseschlauch Long Life ****, mit Unterputz-Einbaukörper
- FR Mélangeur double commande de baignoire 2 trous sur pied, réglage mécanique, inverseur 2 sorties, bec déverseur longueur 263 mm, douchette anticalcaire en métal, flexible long life****, avec corps d'encastrement
- EN Dual-control floor-standing 2-hole bathtub mixer, with mechanical mixing, 2-outlet diverter, spout length 263 mm, metal anti-scale hand shower, long-life hose****, complete with recessed part
- ES Mezclador bimando para bañera, 2 orificios, de suelo, con mezcla mecánica, inversor de 2 salidas, caño con boca de salida de 263 mm, ducha de mano antical de metal, flexo Long Life****, dotado de cuerpo empotrado

CRIRT108

- | | | | | |
|----------|---------------|--------------------------------|----------------------------|--|
| 51 cromo | 13 nero opaco | 34P oro rosa
spazzolato PVD | 46P oro rosa
lucido PVD | 75 cromo nero
spazzolato
77 metallic
spazzolato |
|----------|---------------|--------------------------------|----------------------------|--|

96P gold brass
spazzolato PVD

CRIRT108

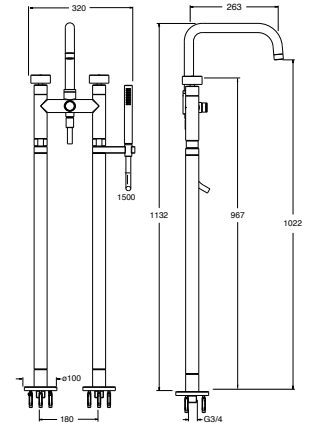

9 1/2 min (3 bar)

CRIVT4809Q00

CRIVT4909Q00

CRIRT162



CRIRT162

- IT con deviatore a 2 uscite
- DE mit 2 wenge umsteller
- FR avec inverseur 2 sorties
- EN with 2 outlet diverter
- ES con desviador 2 salidas

- IT Set esterno bicomando doccia/vasca 3 fori a parete, con miscelazione meccanica, deviatore, da completarsi con parte incasso CRICS115 (comandi laterali)
- DE 3-Loch Fertigmontageset Wannen-/Brause-Zweigriffbatterie für Wandmontag, mit mechanischer Mischung, zu vervollständigen mit Unterputz-Einbaukörper CRICS115 (seitliche Kartuschen)
- FR Groupe extérieur double commande mural douche/baignoire 3 trous, réglage mécanique, à compléter avec le corps d'encastrement CRICS115 (commandes latérales)
- EN External dual-control wall-mounted 3-hole shower/bathtub set, with mechanical mixing, for completion with recessed part CRICS115 (controls on the sides)
- ES Kit exterior bimando para ducha/bañera, 3 orificios, de pared, con mezcla mecánica, a completar con cuerpo empotrado CRICS115 (mandos laterales)

CRIRT162

- | | | | | |
|----------|---------------|--------------------------------|----------------------------|--|
| 51 cromo | 13 nero opaco | 34P oro rosa
spazzolato PVD | 46P oro rosa
lucido PVD | 75 cromo nero
spazzolato
77 metallic
spazzolato |
|----------|---------------|--------------------------------|----------------------------|--|

96P gold brass
spazzolato PVD

CRIRT163

- | | | | | |
|----------|---------------|--------------------------------|----------------------------|--|
| 51 cromo | 13 nero opaco | 34P oro rosa
spazzolato PVD | 46P oro rosa
lucido PVD | 75 cromo nero
spazzolato
77 metallic
spazzolato |
|----------|---------------|--------------------------------|----------------------------|--|

96P gold brass
spazzolato PVD

CRIRT162/CRIRT163

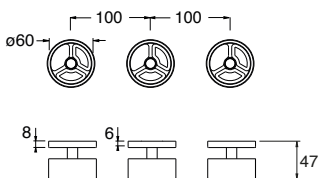

CRICS115

CRIVT5889Q00

CRIVT5890Q00

CRICR19477Q00

CRIVT5889Q00

CRIVT5890Q00

CRICR18496Q00

CRIRT163

- IT con deviatore a 3 uscite
- DE mit 3 wenge umsteller
- FR avec inverseur 3 sorties
- EN with 3 outlet diverter
- ES con desviador 3 salidas

CRIRT165



- IT Set esterno bicomando vasca 5 fori a parete, con miscelazione meccanica, bocca con punto d'erogazione 230 mm, doccetta anticalcare in metallo, supporto fisso, presa d'acqua, flessibile long life****, da completarsi con parte incasso CRICS115 (comandi laterali)
- DE 5-Loch Fertigmontageset Wannen-Zweigriffbatterie für Wandmontage, mit mechanischer Mischung, Auslauflänge 230 mm, Handbrause mit Antikalk-System aus Metall, Halter für Wandmontage, Wandanschlussbogen, Brauseschlauch Long Life****, inkl. Unterputz-Einbaukörper CRICS115 (seitliche Kartuschen)
- FR Groupe extérieur double commande mural de baignoire 5 trous, réglage mécanique, bec déverseur longueur 230 mm, douchette anticalcaire en métal, support fixe, prise d'eau, flexible long life****, à compléter avec le corps d'encastrement CRICS115 (commandes latérales)
- EN External dual-control wall-mounted 5-hole bathtub set, with mechanical mixing, spout length 230 mm, metal anti-scale hand shower, fixed support, water outlet, long-life hose****, for completion with recessed part CRICS115 (controls on the sides)
- ES Kit exterior bimando para bañera, 5 orificios, de pared, con mezcla mecánica, caño con boca de salida de 230 mm, ducha de mano antical de metal, soporte fijo, toma de agua, flexo Long Life****, a completar con cuerpo empotrado CRICS115 (mandos laterales)

CRIRT165

51 cromo	13 nero opaco	34P oro rosa spazzolato PVD	46P oro rosa lucido PVD	75 cromo nero spazzolato 77 metallic spazzolato
----------	---------------	--------------------------------	----------------------------	--

96P gold brass
spazzolato PVD

CRIRT165

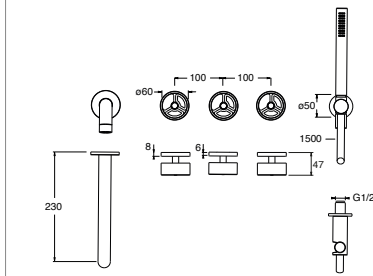

CRIRT122



- IT Miscelatore bicomando bordo vasca 4 fori da piano ispezionabile, con miscelazione meccanica, deviatore a 2 uscite, doccetta anticalcare estraibile in metallo e FOLLOW ME *****, completo di parte incasso
- DE Zur Reinigung demontierbare 4-Loch Wannenrand-Zweigriffbatterie, mit mechanischer Mischung, 2-Wege-Umsteller, ausziehbarer Handbrause aus Metall mit Antikalk-System, FOLLOW ME**** und Unterputz-Einbaukörper
- FR Mélangeur double commande bord baignoire 4 trous sur plage accessible pour l'inspection, réglage mécanique, inverseur 2 sorties, douchette anticalcaire extractible en métal et FOLLOW ME *****, avec corps d'encastrement
- EN Inspectable dual-control deck-mounted 4-hole bathtub edge mixer, with mechanical mixing, 2-outlet diverter, metal extractable anti-scale hand shower and FOLLOW ME*****, complete with recessed part
- ES Mezclador bimando para borde bañera, 4 orificios, de repisa, inspeccionable, con mezcla mecánica, inversor de 2 salidas, ducha de mano antical extraíble de metal y FOLLOW ME*****, dotado de cuerpo empotrado

CRIRT122

51 cromo	13 nero opaco	34P oro rosa spazzolato PVD	46P oro rosa lucido PVD	75 cromo nero spazzolato 77 metallic spazzolato
----------	---------------	--------------------------------	----------------------------	--

96P gold brass
spazzolato PVD

CRIRT122

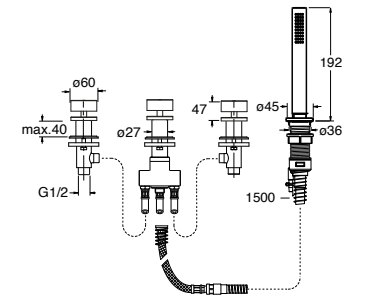

CRIRT121



- IT Miscelatore bicomando bordo vasca 5 fori da piano ispezionabile, con miscelazione meccanica, deviatore a 2 uscite, bocca con punto d'erogazione 210 mm, doccetta anticalcare estraibile in metallo e FOLLOW ME *****, completo di parte incasso
- DE Zur Reinigung demontierbare 5-Loch Wannenrand-Zweigriffbatterie, mit mechanischer Mischung, 2-Wege-Umsteller, Auslauflänge 210 mm, ausziehbarer Handbrause aus Metall mit Antikalk-System, FOLLOW ME*****, inkl. Unterputz-Einbaukörper
- FR Mélangeur double commande bord baignoire 5 trous sur plage accessible pour l'inspection, réglage mécanique, inverseur 2 sorties, bec déverseur longueur 210 mm, douchette anticalcaire extractible en métal et FOLLOW ME *****, avec corps d'encastrement
- EN Inspectable dual-control deck-mounted 5-hole bath edge mixer, with mechanical mixing, 2-outlet diverter, spout length 210 mm, metal extractable anti-scale hand shower and FOLLOW ME*****, complete with recessed part
- ES Mezclador bimando para borde bañera, 5 orificios, de repisa, inspeccionable, con mezcla mecánica, inversor de 2 salidas, caño con boca de salida de 210 mm, ducha de mano antical extraíble de metal y FOLLOW ME*****, dotado de cuerpo empotrado

CRIRT121

51 cromo	13 nero opaco	34P oro rosa spazzolato PVD	46P oro rosa lucido PVD	75 cromo nero spazzolato 77 metallic spazzolato
----------	---------------	--------------------------------	----------------------------	--

96P gold brass
spazzolato PVD

CRIRT121

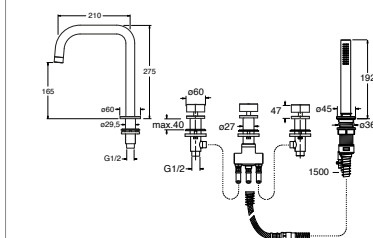

CRIES484

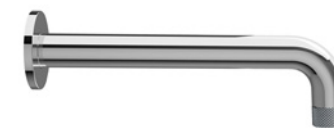

- IT Bocca a parete, attacco da 1/2", punto d'erogazione 230 mm
- DE Wandauslauf, Anschluss 1/2", Auslauflänge 230 mm
- FR Bec déverseur mural, raccord 1/2", longueur 230 mm
- EN Wall-mounted spout, 1/2" connection, spout length 230 mm
- ES Caño de pared, conexión de 1/2", boca de salida de 230 mm

CRIES484

Per completare l'offerta, consultare il listino pag. 76

Um das Angebot zu vervollständigen, konsultieren Sie die Preisliste auf Seite 76

Pour compléter l'offre, consultez la grille tarifaire en page 76

To complete the offer, consult the price list on page 76

Para completar la oferta, consulte la lista de precios en la página 76

CRIES484

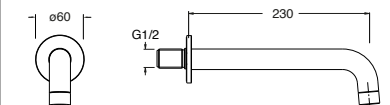

CRIRT618



IT Rubinetto d'arresto da 1/2" a parete
 DE Absperrventil für Wandmontage 1/2"
 FR Robinet d'arrêt 1/2" mural
 EN Wall-mounted 1/2" shut-off tap
 ES Llave de paso de 1/2" de pared

CRIRT618

51 cromo 13 nero opaco 34P oro rosa
 spazzolato PVD 46P oro rosa
 lucido PVD 75 cromo nero
 spazzolato
 77 metallic
 spazzolato

96P gold brass
 spazzolato PVD

CRIRT618

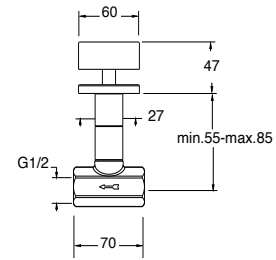

CRIRT619



IT Rubinetto d'arresto da 3/4" a parete
 DE Absperrventil für Wandmontage 3/4"
 FR Robinet d'arrêt 3/4" mural
 EN Wall-mounted 3/4" shut-off tap
 ES Llave de paso de 3/4" de pared

CRIRT619

51 cromo 13 nero opaco 34P oro rosa
 spazzolato PVD 46P oro rosa
 lucido PVD 75 cromo nero
 spazzolato
 77 metallic
 spazzolato

96P gold brass
 spazzolato PVD

CRIRT619

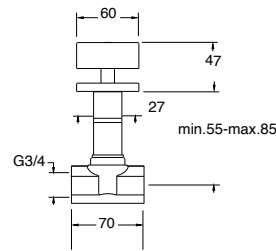

CRIRT526



IT Miscelatore bicomando cucina monoforo da piano, con miscelazione meccanica, bocca orientabile, altezza 305 mm
 DE 1-Loch Zweigriff-Mischbatterie für die Küche, mit mechanischer Mischung, verstellbarem Auslauf, Höhe 305 mm
 FR Mélangeur double commande de cuisine monotrou sur plage, réglage mécanique, bec orientable, hauteur 305 mm
 EN Dual-control deck-mounted single-hole kitchen mixer, with mechanical mixing, swivel spout, height 305 mm
 ES Mezclador bimando para cocina, 1 orificio, de repisa, con mezcla mecánica, caño orientable, altura 305 mm

CRIRT526

51 cromo 13 nero opaco 34P oro rosa
 spazzolato PVD 46P oro rosa
 lucido PVD 75 cromo nero
 spazzolato
 77 metallic
 spazzolato

96P gold brass
 spazzolato PVD

CRIRT526

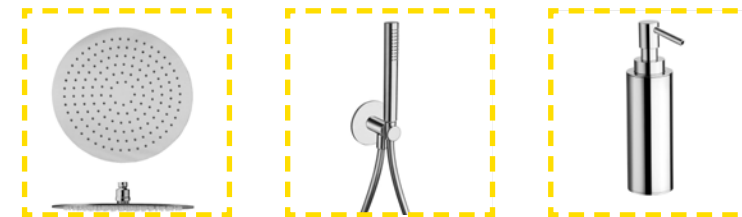
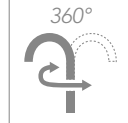
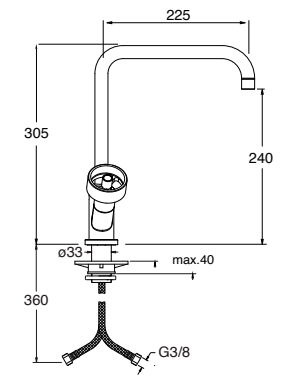

Per completare la formulazione della vostra offerta, vi invitiamo a consultare i capitoli:

- [Completamenti per Doccia/Vasca/Lavabo](#)
- [Soffioni & Bracci Doccia](#)
- [Accessori Contemporary Collection](#)

To complete the drafting of your offer, please see the following chapters:

- [Completions for Shower/Bath/Washbasin](#)
- [Showerheads & Shower Arms](#)
- [Accessories Contemporary Collection](#)

Company



WHO WE ARE

Fondata nel 1949, CRISTINA ha attraversato più di settant'anni di storia italiana capitalizzando i valori di capacità produttiva, tradizione e credibilità, intercettando i trend di innovazione e di internazionalizzazione, posizionandosi tra i brand leader nel settore della rubinetteria. La sinergia con SILFRA Bathroom Tech (1987) - una delle più affermate realtà nel comparto tecnico idrosanitario - e l'entrata nel gruppo Caleffi (2017) hanno accompagnato e sostenuto il costante processo di crescita, evoluzione e sviluppo di CRISTINA verso una realtà sempre più sostenibile. Sempre nel 2017 viene inaugurato lo showroom proprietario a Milano,

con l'obiettivo di implementare il dialogo con progettisti e architetti e per proporre eventi e rafforzare l'immagine aziendale. Nel 2020, CRISTINA Rubinetterie rinnova la strategia per determinare il percorso dell'azienda nel prossimo futuro, orientato al design, al lancio di nuove linee e con una grande attenzione alla sostenibilità e ai metodi di produzione meno impattanti. L'anno seguente nasce "From Yellow to.. Green!" un claim che vuole trasmettere l'impegno di CRISTINA Rubinetterie a diventare una realtà sempre più green. Importanti cambiamenti in termini di logistica, sinergia e nuovi sistemi organizzativi: in meno di cinque anni CRISTINA è passata dallo storytelling a un concretissimo storydoing.

Founded in 1949, CRISTINA has gone through more than seventy years of Italian history, capitalising on values of production capacity, tradition, and credibility, intercepting trends of innovation and internationalisation, positioning itself as one of the leading brands in the tap industry. The synergy with SILFRA Bathroom Tech (1987) - one of the most established companies in the hydrosanitary technical sector and the entry into the Caleffi group in 2017 accompanied and supported CRISTINA's constant process of growth, evolution, and development towards an increasingly sustainable reality. Also in 2017, the opening of the company-owned showroom in Milan, with the goal of enhancing dialogue with designers and architects through work meetings and design projects, as well as proposing events and strengthening the company's image. In 2020, CRISTINA Rubinetterie renewed its strategy to determine the company's path in the near future, focused on design, launching new product lines, and with great attention to sustainability and less impactful production methods. The following year, "From Yellow to.. Green!" was born as a slogan that aims to convey CRISTINA Rubinetterie's commitment to becoming an increasingly green company. Important changes in logistics, synergy, and new organisational systems: in less than five years, CRISTINA has gone from storytelling to concrete storydoing.

SAVOIR FAIRE

La ricerca di innovazione è alla base di ogni progetto, realizzato con macchinari all'avanguardia e supportato da artigiani specializzati che intervengono nelle fasi più delicate del processo produttivo con soluzioni ideate per assicurare il massimo valore estetico. Tutto questo si traduce anche in quella cura del dettaglio che contribuisce all'unicità del Made in Italy e ne racchiude tutta la cultura. Gestire la produzione internamente risulta strategico perché assicura il puntuale controllo, l'eticità, la sostenibilità e la continuità produttiva in caso di emergenze e produce soprattutto un importante flusso di conoscenza, di apprendimento e di gratificazione di tutti gli stakeholder coinvolti, con conseguente ottimizzazione delle lavorazioni. In quest'ottica di ottimizzazione e di innovazione, ognuno dei quattro stabilimenti produttivi, situati nel novarese a pochi chilometri di distanza, è dedicato a una precisa lavorazione. Nei due stabilimenti a Gozzano sono localizzati gli impianti di logistica centralizzata con i magazzini intensivi per la preparazione dei semilavorati. Nella sede di Gargallo convergono i reparti di cromatura, finitura galvanica, mentre il polo logistico di Fontaneto d'Agogna è sede dei reparti di stampaggio plastica, delle isole di saldatura e marcatura laser e di assemblaggio dei prodotti dei brand SILFRA Bathroom Tech e CRISTINA Rubinetterie.

The pursuit of innovation lies at the heart of every project: their state-of-the-art machinery is supported by skilled artisans who intervene in the most delicate phases of the production process, ensuring maximum aesthetic value. This attention to detail contributes to the uniqueness of the Made in Italy brand and encapsulates all its culture.

Managing production internally is a strategic move, ensuring punctual control, ethical and sustainable production, and continuity of production in case of emergencies. It also generates a significant flow of knowledge, learning, and satisfaction for all stakeholders involved, resulting in the optimization of work processes. In this context of optimization and innovation, each of the four production plants located in the Novara area is dedicated to a specific production process. The two plants in Gozzano house centralized logistics

facilities with intensive warehouses for the preparation of semi-finished products. At the Gargallo site, the chrome-plating and galvanizing finishing departments converge, while the logistics hub in Fontaneto d'Agogna houses the plastic moulding departments, welding and laser marking stations, and product assembly departments for the SILFRA Bathroom Tech and CRISTINA Rubinetterie brands.



RESEARCH & DEVELOPMENT

Il forte investimento di capitali e risorse umane nell'attività di ricerca e sviluppo è poi un ulteriore tratto fondante in CRISTINA Rubinetterie, dove opera il CRISTINA Design Lab, dipartimento interno totalmente dedicato alla creazione di soluzioni innovative in grado di soddisfare le diverse esigenze del cliente. Nel corso degli anni, infatti, l'azienda si è contraddistinta sul mercato per essere pioniera di stili e tendenze: è stata tra le prime ad introdurre, nel 1968 in Europa, il miscelatore termostatico e a proporre una gamma di 100 colorazioni superficiali, grazie all'apertura di un reparto dedicato alla verniciatura e, successivamente, di uno alla galvanica, rivoluzionando così il comparto. La ricerca della qualità è un obiettivo strategico non solo nella progettazione ma anche nella ricerca di materie prime eccellenti, ecologiche, dalle straordinarie prestazioni

tecniche e in grado di resistere nel tempo, mantenendo intatta l'estetica. Ne è un esempio, l'utilizzo già dal 2003 dell'acciaio inox (garantito dal marchio di qualità rilasciato dal Centro Inox) a cui l'azienda ha dedicato un'intera divisione. Attenzione alla forma e conseguente evoluzione estetica sono determinanti per il successo di un prodotto. In costante ricerca di sguardi nuovi, l'azienda coinvolge un sempre più ampio team di designers la cui progettualità viene sviluppata in collaborazione con il CRISTINA Design Lab.

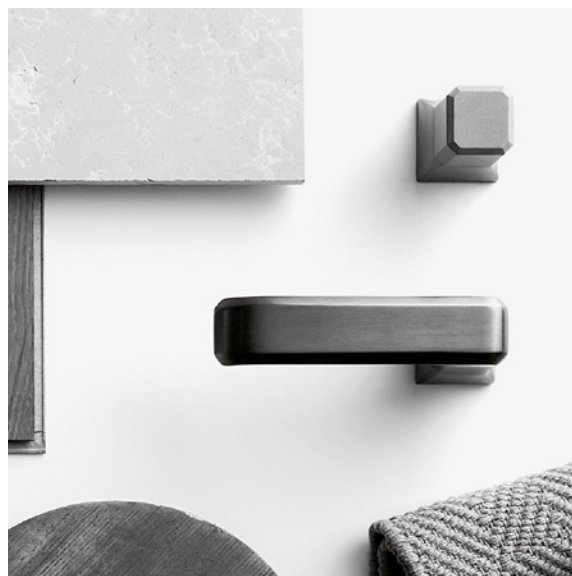

The strong investment of capital and human resources in research and development is another fundamental trait of CRISTINA Rubinetterie, where the

CRISTINA Design Lab operates as an internal department entirely dedicated to creating innovative solutions capable of meeting the diverse needs of customers.

Over the years, the company has distinguished itself in the market for being a pioneer of styles and trends: it was among the first in Europe to introduce the thermostatic mixer in 1968 and to offer a range of 100 surface colors, thanks to the opening of a dedicated painting department and subsequently a galvanizing department, thus revolutionizing the sector. The pursuit of quality is a strategic objective not only in design but also in the search for excellent, ecological raw materials with extraordinary technical performance that can withstand the test of time while maintaining their aesthetic value. An example of this is the use of stainless steel (guaranteed by the quality mark issued by Centro Inox) which the company has dedicated an entire division to since 2003.

Attention to form and subsequent aesthetic evolution are crucial to the success of a product. In constant search of fresh perspectives, the company involves an increasingly wider team of designers whose creativity is developed in collaboration with the CRISTINA Design Lab.

CRISTINA BRERA SHOWROOM

Inaugurato nel 2017, lo showroom proprietario situato a Milano nel cuore del Brera Design District, gioca un ruolo di vetrina e centro propulsore di dibattito e confronto con la clientela e il mondo dell'architettura. Nel 2023, lo spazio è stato sottoposto ad una revisione progettuale: l'esigenza era quella di proiettare la nuova immagine aziendale stabilendo con il visitatore una comunicazione immediata e aperta con un alto grado di espressività. Elisa Ossino, incaricata del progetto di interior dello spazio (200 mq su due livelli), ha riguardato innanzitutto la modalità di esposizione, per cui il rubinetto, considerato come oggetto, doveva essere percepito non solo dal punto di vista estetico o materico, quanto soprattutto per la funzionalità insita nel differente flusso dell'acqua, inteso come componente essenziale. Da qui l'idea di scardinare un'asettica esposizione in favore di un approccio emozionale, dato in primis dall'interazione del visitatore con elementi funzionanti.

Un polo creativo che esce dalla logica dello showroom tradizionale riscrivendo l'idea dello spazio espositivo, in cui gli oggetti concorrono a creare un'installazione, trasformandolo in un ambiente accogliente, perfetto per ospitare clienti, architetti, eventi e, perché no, anche mostre d'arte.

Inaugurated in 2017, the flagship showroom located in the heart of Milan's Brera Design District plays a role as a showcase and driving force for debate and discussion with its customers and the world of architecture. In 2023, the space underwent a redesign to project the new corporate image by establishing immediate and open communication with visitors with a high degree of expressiveness. Elisa Ossino, in charge of the interior design project for the 200 square meter space on two levels, first reconsidered the mode of display, for which the faucet, considered as an object, had to be perceived not only from an aesthetic or material perspective, but especially for the functionality inherent in the different flow of water, seen as an essential component. Hence the idea of breaking down an aseptic exhibition in favour of an emotional approach, given primarily by the interaction of the visitor with functioning elements.

A creative hub that goes beyond the logic of traditional showrooms, rewriting the idea of the exhibition space, in which objects contribute to creating an installation, transforming it into a welcoming environment, perfect for hosting clients, architects, events, and why not, also art exhibitions.



Company Certifications



QUALITY SYSTEM
CERTIFICATION ISO 9001



QUALITY SYSTEM
CERTIFICATION ISO 45001



LEED CERTIFICATIONS

GARANZIA, QUALITÀ E AMBIENTE

Per CRISTINA la soddisfazione del cliente è il principale obiettivo; prioritario è l'impegno a offrire sempre prodotti e servizi di elevata qualità. L'attenta scelta delle materie prime e il rigoroso controllo di ciascuna fase del processo produttivo assicurano un prodotto affidabile, dalle grandi prestazioni.

WARRANTY, QUALITY AND ENVIRONNEMENT

For CRISTINA, customer satisfaction is the main objective; our commitment to always offer high quality products and services takes top priority. Our reliable products, ensuring great performance, are the result of the careful selection of raw materials and the rigorous control at each stage of the production process.

TECNOLOGIE

CRISTINA investe in ricerca e sviluppo e realizza i propri prodotti utilizzando le tecnologie più all'avanguardia.

Il risultato? Ottime prestazioni, massima affidabilità ed estrema praticità di utilizzo, il tutto unito alla particolare attenzione rivolta.

TECHNOLOGIES

CRISTINA invests in research and development and manufactures its products using the latest technology. The result?

Excellent performance, high reliability and extreme ease of use, all this combined with special focus on saving water and energy.

FROM
YELLOW
TO...
GREEN!

Il claim aziendale From Yellow to... Green! si sta sempre più traducendo in una ferma consapevolezza etica e nel conseguente concreto agire.

The company claim From Yellow to... Green! is becoming more and more a firm ethical awareness and consequent concrete action.



- 1- Imprescindibile concetto di sostenibilità alla base dell'intera produzione di CRISTINA.
- 2- Investire nella green economy è un valore fondamentale per alimentare la macchina trasformativa di un'azienda.
- 3- Consapevole che sostenibilità significa tutela del territorio e attenzione per le future generazioni, CRISTINA Rubinetterie, ben lungi da un semplice green washing, sta implementando una serie di iniziative che vedono l'azienda sempre più impegnata nel processo di transizione ecologica.

- 1- Inescapable concept of sustainability at the basis of the entire production of CRISTINA.
- 2- Investing in the green economy is a fundamental value to fuel the transformational machine of a company.
- 3- Aware that sustainability means protecting the territory and caring for future generations, CRISTINA Rubinetterie, far from mere green washing, is implementing a series of initiatives in which the company is increasingly committed to the ecological transition process.

Prima puntata
First Chapter



IMBALLO

Un eco-pack che riguarda tanto la scelta del materiale quanto la veste grafica. La polpa di cartone riciclata e riciclabile ha sostituito infatti la plastica nell'imballaggio dei prodotti, rivelandosi altrettanto performativa durante il trasporto.

PACKAGING

An eco-pack that applies as much to the choice of material as to the graphics. In fact, recycled and recyclable cardboard pulp has replaced plastic in the packaging of the products, proving to be equally performing during transport.

SMALTIMENTO PACKAGING

Un QR code posto all'esterno delle scatole ne indica il corretto smaltimento. Un added-value per l'azienda, attenta alle esigenze dei consumatori, sempre più sensibili all'impatto ambientale.

PACKAGING DISPOSAL

A QR code placed on the outside of the boxes indicates their correct disposal. An added value for the company, which is attentive to the needs of consumers who are becoming more and more environmentally sensitive.

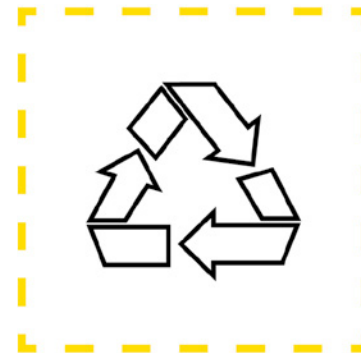

RIFIUTI INDUSTRIALI

I rifiuti di produzione vengono differenziati con sempre maggiore attenzione per permetterne lo smaltimento sempre più specifico per tipologia.

INDUSTRIAL WASTE

Production waste is being sorted with increasing attention to allow more specific disposal by type.

CONSUMO ENERGETICO

Vengono utilizzate progressivamente lampade LED a basso consumo energetico in tutti gli impianti di illuminazione degli stabilimenti.

ENERGY CONSUMPTION

Low-energy LED lamps are progressively used in all plant lighting systems.



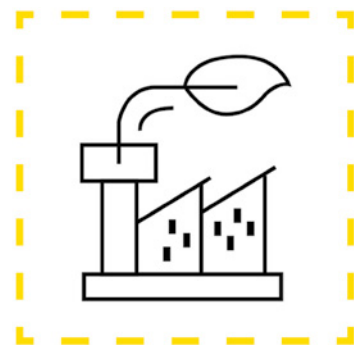

EFFICIENTAMENTO MAGAZZINO

L'azienda ha finalizzato l'aggregazione delle unità di assemblaggio e di spedizione dei prodotti a marchio CRISTINA e SILFRA nell'unica sede di Fontaneto d'Agogna, questo efficientamento di magazzino ha prodotto una migliore gestione del lavoro e delle esigenze produttive, la semplificazione burocratica ed un minor numero di spostamenti nelle operazioni di trasporto volti a ridurre gli sprechi.

WAREHOUSE EFFICIENCIES

The company has finalized the aggregation of the assembly and shipping units of the CRISTINA and SILFRA branded products in the single site of Fontaneto d'Agogna, this warehouse efficiency has led not only to a better management of the work and production flow, but also to the simplification of bureaucratic procedures and fewer transport operations aiming to reduce waste.

AREATORE A RISPARMIO IDRICO

Le serie introdotte dal 2016 contemplano la riduzione del consumo dell'acqua, con progressi sempre più marcati in tema di sostenibilità.

WATER SAVING AERATOR

The series introduced in 2016 include the reduction of water consumption, with increasingly marked progress in the area of sustainability.

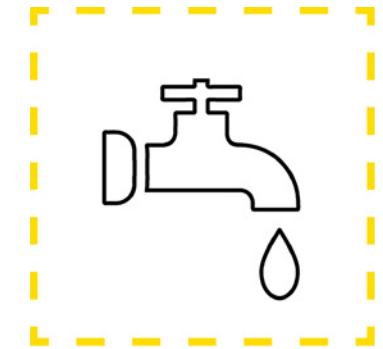

BENESSERE DEL LAVORATORE

La riqualificazione degli spazi interni dello stabilimento, più luminosi, aerati e salubri è volta anche a migliorare il benessere di chi vi lavora.

WORKER WELFARE

The redevelopment of the internal spaces of the plant, which are more luminous, ventilated and salubrious, is also aimed at improving the well-being of the workers.

Graphic Design
Marketing CRISTINA Rubinetterie

CRISTINA SRL a socio unico
via G. Fava, 56
28024 Gozzano (NO) - Italy
T +39 0322 9545
info@cristinagroup.com
cristinarubinetterie.com



CRISTINA srl è in possesso di un Sistema di Gestione Aziendale certificato secondo le norme UNI EN ISO 9001:2015 (Quality) e UNI ISO 45001:2018 (Health and Safety in the workplace).
CRISTINA Srl has a Company Management System certified according to UNI EN ISO 9001:2015 (Quality) e UNI ISO 45001:2018 (Health and Safety in the workplace).

Le immagini presenti sul catalogo ADD WATER mostrano una selezione della gamma CRISTINA Rubinetterie. Per l'offerta completa, vi invitiamo a consultare il Product Catalogue CRISTINA 2023.
The pictures shown in ADD WATER catalogue feature an overview of CRISTINA Rubinetterie offer. We invite you to check CRISTINA Product Catalogue 2023, for the complete range.

L'azienda si riserva il diritto di apportare modifiche che riterrà opportune, utili a migliorare la funzionalità e l'estetica dei propri prodotti senza preavviso.
The company reserves the right to make any appropriate modifications to improve functionality and design of its products without notice.